



INSTALLATION INSTRUCTIONS

Not legal for sale or use in California on any pollution controlled motor vehicle.

70-3082

CHEVROLET / GMC / CADILLAC

2014-19 Silverado 1500 / Sierra 1500

2015-20 Tahoe / Suburban / Yukon / Escalade ESV

V8-5.3L / 6.2L

TOOLS NEEDED:

- Ratchet
- Extension
- 10mm Socket
- Flat Blade Screwdriver
- T10 Torx
- 3mm Allen Key
- 13/16" Wrench
- Side Cutters
- 5/16" Socket / Nut Driver

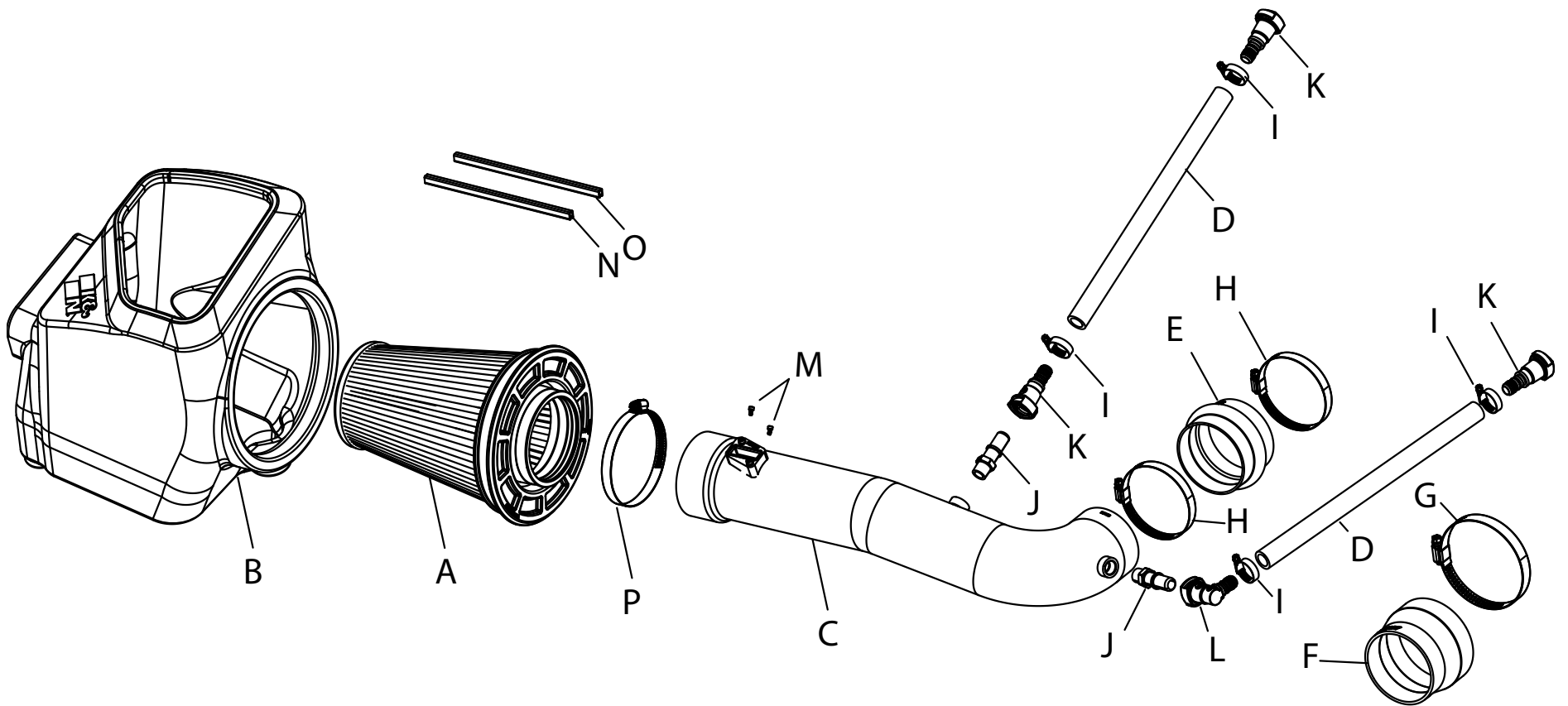

PARTS LIST:

Description	Qty.	Part #	Description	Qty.	Part #	Description	Qty.	Part #
A AIR FILTER	1	RU-5342	G HOSE CLAMP; #64 BLACK	1	08645KA	M BOLT; M4-.7 X 8MM	2	07733
B AIR BOX	1	087608A	H HOSE CLAMP; #56 BLACK	2	08620KA	N CLIP; SNAP-ON, RED	1	088218
C TUBE	1	27685C	I HOSE CLAMP; #10 MINI	4	08411	O CLIP; SNAP-ON, ORANGE	1	088219
D HOSE; 5/8" X 14"L	2	084083	J FITTING; QC 3/8" NPT	2	82637-1	P HOSE CLAMP; #72 BLACK	1	08671KA
E HOSE; HUMP 3.5"	1	08699	K FITTING; QC DISCONNECT	3	08526			
F HOSE; 4" TO 3.5"	1	08497	L FITTING; QC DISCONNECT 90	1	KITFITTING33			

If you need any assistance please call 1-800-858-3333 to speak with a representative in our Customer Service Center before returning the product.

NOTE: FAILURE TO FOLLOW INSTALLATION INSTRUCTIONS AND NOT USING THE PROVIDED HARDWARE MAY DAMAGE THE INTAKE TUBE, THROTTLE BODY AND ENGINE.

TO START:

1. Turn off the ignition and disconnect the negative battery cable.
NOTE: Disconnecting the negative battery cable erases pre-programmed electronic memories. Write down all memory settings before disconnecting the negative battery cable. Some radios will require an anti-theft code to be entered after the battery is reconnected. The anti-theft code is typically supplied with your owner's manual. In the event your vehicles anti-theft code cannot be recovered, contact an authorized dealership to obtain your vehicles anti-theft code.



2. Release the red locking tab and then disconnect the mass air sensor electrical connection, unhook the wiring harness from the air filter housing.



3. Depress the grey locking tabs, then disconnect the CCV hoses from the intake plenum.



4. Loosen the hose clamps that secure the intake plenum to the throttle body and air filter housing.



5. Disconnect the plenum from the air filter housing and throttle body and remove from the engine.



6. Lift the air filter housing up and then slide slightly to the right, then remove the housing from the vehicle.



7. Remove the four bolts that secure the air filter housing mounting plate and then remove the plate from the vehicle.

NOTE: Three of the bolts will be reused in the next step.



7A. On Cadillac Escalade & GMC Yukon vehicles, Chevrolet suburban and tahoe, remove the fourteen plastic pins that secure the radiator cover and then remove the radiator cover from the vehicle.



7B. Remove the two bolts that secure the fender to core support brace and remove the brace from the vehicle. **NOTE: This brace will no longer be used on Cadillac Escalade & GMC Yukon vehicles only.**



8. Install the K&N air filter housing so the fresh air intake passes through the opening in the inner fender and then secure the three factory bolts removed in step #7. **NOTE: the wiring harness along the bottom the mounting plate may need to be adjusted for best fit.**



9. Attach the filter clips to the pleats on the air filter align and push down. Passenger side filters, place orange clip on top and red on bottom.



10. Install the K&N air filter into the K&N air filter housing.



11. Depress the grey locking tabs and then remove the factory CCV hoses from the valve covers.

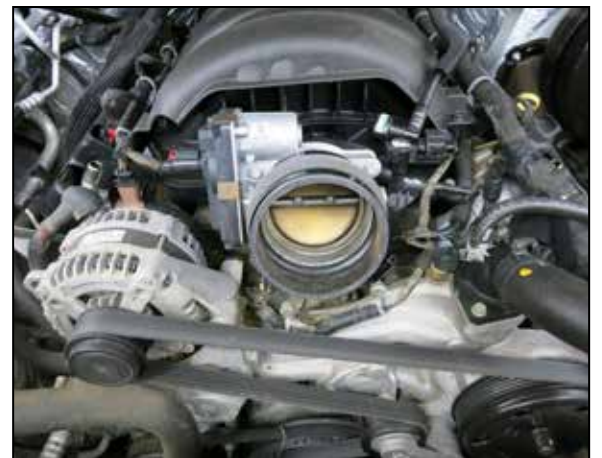

12. Install the step coupler (#08699) on 5.3L engines, hump coupler (#08497) on 6.2L engines and secure with the provided hose clamp. Tighten clamps using 5/16" socket or nut driver. **Note: Do not over tighten clamps.**



13. With T10 torx bit, loosen the 2 screws and remove the MAF sensor from the airbox.



14. Install the mass air sensor assembly into the K&N intake tube so the opening is towards the filter end of the tube. Secure the assembly with the provided hardware.



15. Install the provided CCV quick connect fittings into the K&N intake tube as shown.
NOTE: the CCV fittings utilize 3/8npt threads, hand tighten the fittings and then use a wrench to tighten one revolution.



16. Install the K&N intake tube assembly into the air filter and then into the coupler, adjust the tube for best fit and then secure with the provided hose clamps. Tighten clamps using 5/16" socket or nut driver.
Note: Do not over tighten clamps.



17. Trim one of the provided CCV hoses to 12 inches. Install the provided CCV quick connect fittings into the CCV hoses as shown. **Note: Attach the 90deg. CCV fitting to the 12" hose.**



18. Install the CCV hose assembly onto the passenger side and driver side. If vehicle is equipped with engine cover, use the 90 degree quick connect closest to the MAF sensor to clear cover as shown in image.



19. Reconnect the mass air sensor electrical connection.



20. Install the provided K&N decal to the intake tube at desired position.



21. Reconnect the vehicle's negative battery cable. Double check to make sure everything is tight and properly positioned before starting the vehicle.

22. It will be necessary for all K&N® high flow intake systems to be checked periodically for realignment, clearance and tightening of all connections. Failure to follow the above instructions or proper maintenance may void warranty.

23. **K&N AIR FILTER MONITOR LIGHT:** Some vehicles are equipped with a "Air Filter Monitor" system that will send a message to the instrument cluster indicating that the air filter needs to be replaced. This system is calibrated for the OEM intake system and air filter and will not be accurate when K&N products are in use. Always refer to WWW.KNFILTERS.COM for K&N air filter service procedures. The "Air Filter Monitor" system must be disabled to prevent the monitor from setting on and causing a factory dealership visit to rest the system. Follow the "Air Filter Monitor" system procedure listed in the factory owners manual.

ROAD TESTING:

1. Start the engine with the transmission in neutral or park, and the parking brake engaged. Listen for air leaks or odd noises. For air leaks secure hoses and connections. For odd noises, find cause and repair before proceeding. This kit will function identically to the factory system except for being louder and much more responsive.

2. Test drive the vehicle. Listen for odd noises or rattles and fix as necessary.

3. If road test is fine, you can now enjoy the added power and performance from your kit.

4. K&N Engineering, Inc., requires cleaning the intake system's air filter element every 50,000 miles. When used in dusty or off-road environments, our filters will require cleaning more often. We recommend that you visually inspect your filter once every 25,000 miles to determine if the screen is still visible. When the screen is no longer visible some place on the filter element, it is time to clean it. To clean, purchase our Synthetic Filter Cleaner, part number 99-0624 and follow the easy instructions.